

<b>THE SAILOR</b>					<b>8x32 R</b>	
						<p>2 1</p> <p><b>RL</b></p>

RSCDS Book 24.4

3C/4C longwise set.

<b>THE FIREWORKS REEL</b>					<b>8x32 R</b>	

Anselm Lingnau, 2009, [my.strathspey.org/u/anselm/dances/](http://my.strathspey.org/u/anselm/dances/), RSCDS Book 48.11

3C/4C longwise set.

<b>FORTY AND COUNTING</b>					<b>8x40 R</b>	
		<p>Chain progression</p>				

Malcolm Brown, 2015, RSCDS Book 52.4

3C/4C longwise set.

<b>KATRINA'S KAPERS</b>		<b>5x32 R</b>			
<p><b>S</b> <math>\curvearrowright</math> <b>S</b></p>	<p><b>S</b> <math>\curvearrowright</math> <b>S</b></p>	<p><b>X<sub>R</sub></b></p>	<p><b>RA</b></p>		
<p>1x 3x</p>		<p><b>T<sub>R</sub></b></p>	<p>1 3</p>	<p><b>T<sub>R</sub><sup>3</sup><sub>4</sub></b> <math>\curvearrowright</math> 1</p>	<p>2 4 1 5 3</p> <p><b>(4) T<sub>R</sub> T<sub>L</sub> (4)</b></p>

Andrew Osborne, 2017

5C/5C longwise set.

<b>FISHERMAN GINGER'S REEL</b>		<b>8x32 R</b>	
<p><b>T<sub>R</sub></b> <math>\curvearrowright</math> 1</p>	<p>1 3</p>	<p>2 1 3</p>	<p><b>T<sub>R</sub>1<sup>1</sup><sub>2</sub></b></p>
<p>2 1 3</p>	<p><b>T<sub>R</sub>1<sup>1</sup><sub>2</sub></b></p>	<p>2 1 3 ALL</p> <p>6 slip steps</p>	<p>ALL</p>

Gaye and Damon Collin, 2001, SCD is all around the World

3C/4C longwise set.

<b>THE RAVEN'S DANCE</b>		<b>8x32 J</b>	
<p>Double Figure of 8</p>	<p>Change lead on bars 3 &amp; 7</p>	<p>2 1 3</p>	

Derek Haynes, Carnforth Collection 5

3C/4C longwise set.

<b>FLORA'S FANCY</b>		<b>8x32 J</b>	
<p><b>S</b> <math>\curvearrowright</math> 1</p>	<p><b>RA</b></p>	<p><b>S T<sub>R</sub><sup>3</sup><sub>4</sub></b></p>	<p><b>LA</b></p>

RSCDS Tucson & Seven Pipers Scottish Society, RSCDS Book 49.8

3C/4C longwise set.

<b>LUCKENBOOTH BROOCH</b>			<b>8x32 J</b>
		<b>RL</b>	1st time: $T_{R1\frac{3}{4}}$ to Prom hold 2nd time: $T_{R\frac{3}{4}} \rightarrow$

John Bowie Dickson, Glendaroch Sheet 28

3C/4C longwise set.

<b>THE ROAD TO MCGREGOR</b>		<b>4x32 S</b>	
1 3 $\xrightarrow{N} T_B$	1 3 $\xleftarrow{N} T_B$		
1 2 3 4 <b>S &amp; LINK</b>	1 3 $T_{\diamond} S$		3 1      2 3 4 1 $T_{R\frac{3}{4}}$ <b>S</b>

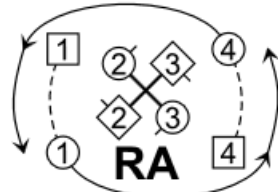
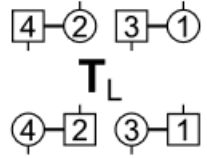
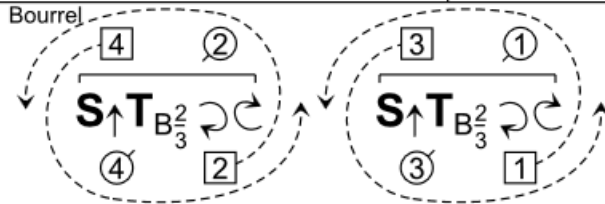

Andrew Hodgson, 2013, Happy Blues (Pretoria 45th Anniversary)

4C/4C longwise set.

<b>THE GREY WANDERER</b>		2C & 4C start on opposite sides	<b>4x48 S</b>												
1 2x 3 4x <b>S</b> & LINK	2x 1 4 x 3 <b>S</b> & LINK	①-② ③-④ 	<table style="width: 100%; border: none;"> <tr> <td style="text-align: center;">①</td> <td style="text-align: center;">③</td> <td style="text-align: center;"><b>S</b></td> <td style="text-align: center;">1 2x 3 4x</td> </tr> <tr> <td style="text-align: center;">①-②</td> <td style="text-align: center;">③-④</td> <td style="text-align: center;"><b>T<sub>R</sub></b></td> <td style="text-align: center;"><b>RA</b></td> </tr> <tr> <td style="text-align: center;">②</td> <td style="text-align: center;">④</td> <td style="text-align: center;"><b>S</b></td> <td></td> </tr> </table>	①	③	<b>S</b>	1 2x 3 4x	①-②	③-④	<b>T<sub>R</sub></b>	<b>RA</b>	②	④	<b>S</b>	
①	③	<b>S</b>	1 2x 3 4x												
①-②	③-④	<b>T<sub>R</sub></b>	<b>RA</b>												
②	④	<b>S</b>													
ALL ↻	2 1x 4 3x <b>LA</b>	 <b>RA</b>	 <b>T<sub>L</sub></b>												
Bourrel 		②-② ④-④ ①-① ③-③ <b>S T<sub>B<sub>4</sub><sup>3</sup></sub></b>	2x 4 1x 3 <b>8</b>												
Repeat with gender roles reversed, ie Ladies dance reel, and set in Bourrel															

Iain Boyd, 1982, Lord of the Rings Collection

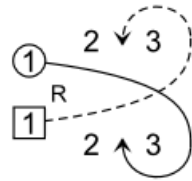
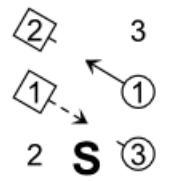
4C/4C longwise set.

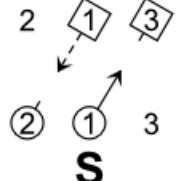
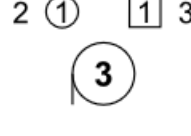
<b>MIDSUMMER COMMON</b>		<b>8x32 S</b>
<b>S T<sub>R<sub>2</sub><sup>1</sup></sub></b>		 <b>T<sub>B</sub></b>
2 ① ③ ① 3 	 <b>S</b>	<b>T<sub>B<sub>4</sub><sup>3</sup></sub></b>
 <b>S T<sub>◇</sub></b>	<b>S T<sub>◇</sub></b>	2 1 <b>P</b>

Tom and Lindsey Ibbotson, 2013, RSCDS Book 49.3

3C/4C longwise set.