

<b>EH3 7AF</b>		<b>8x32 J</b>	
	1 2 3 <b>PROM</b> 1		

Roy Goldring, 1998, RSCDS Book 40.6

3C/4C longwise set.

<b>MRS STUART LINNELL</b>		<b>8x40 R</b>	

John Bayly, 1976, Imperial 3.16

3C/4C longwise set.

<b>CITY OF BELFAST</b>		<b>3x32 S</b>	

Lucy Mulholland, 2007, Belfast Diamond Jubilee Book, RSCDS Book 48.6

3C/3C longwise set.

<b>FAREWELL TO BALFOUR ROAD</b>					
5 couples, 2C start on bar 17					
<b>96 J</b>					
1 2 	1 2 <b>S</b> & LINK	1 3 <b>S</b> & LINK	1 4 5 	<b>S</b> X R	1x <b>S</b> X L

Andrew Buxton, 2015, RSCDS Book 52.7

5C/5C longwise set.

<b>THE DUNDEE DRAGON</b>		<b>8x32 R</b>	

Bill Forbes, Craigievar Book 5

3C/4C longwise set.

<b>LINNEA'S STRATHSPEY</b>		<b>8x32 S</b>	

Tim Wilson, 2001, Dunsmuir Dances, RSCDS Book 47.2

3C/4C longwise set.

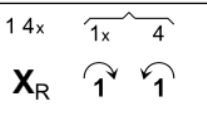
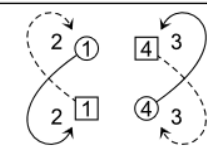
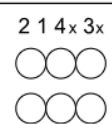
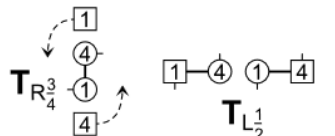
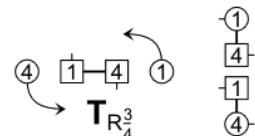
<b>JAMES GRAY</b>		3C & 4C cross on 2nd chord	<b>4x32 J</b>
1 4x <b>X<sub>R</sub></b> 		1 4x <b>RL</b>	2 1 4x 3x 
		to 2 4 1x 3x	

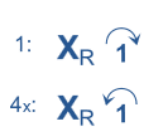
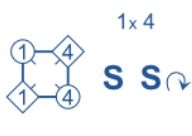
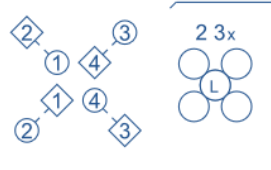
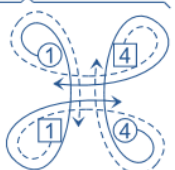
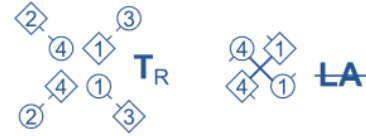
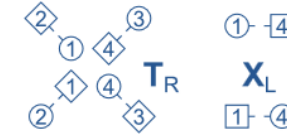
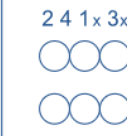

Ronella Burrows, RSCDS Book 42.10

4C/4C longwise set.

<b>REEL OF THE PUFFINS</b>		3C & 4C cross on 2nd chord	<b>4x32 R</b>
1: <b>X<sub>R</sub></b> 4x: <b>X<sub>R</sub></b> 	1x 4 <b>S S</b> 		
		2 4 1x 3x 	

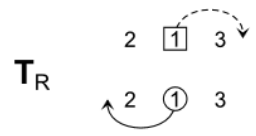
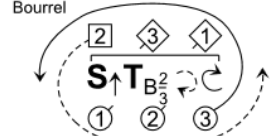
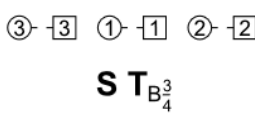
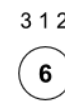

John Bowie Dickson, 1998, Dunedin Dances 5.1

4C/4C longwise set.

<b>MISS ELEANOR</b>		<b>3x32 S</b>
	<b>S</b> 	<b>T<sub>R</sub></b> 
Bourrel 		3 1 2 

Ann Dix, 2013, RSCDS Book 49.5

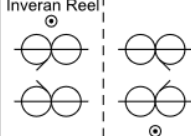
3C/3C longwise set.

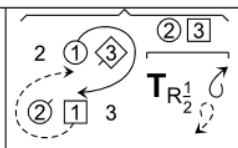
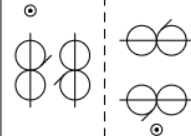
<b>RAMADAN-CE</b>		<b>8x32 R</b>	
Inveran Reel 	<b>X<sub>R</sub></b> 	<b>T<sub>R</sub></b> 	

John Drewry, 2000, Turkish Set

3C/4C longwise set.

Dances in blue will be walked through

~~~~~INTERVAL~~~~~

| <b>THE RUTLAND REEL</b> |  |          |            |                                                            | <b>8x40 R</b> |         |
|-------------------------|--|----------|------------|------------------------------------------------------------|---------------|---------|
| S 1                     |  | 2 1x<br> | 2 1x 3<br> | ①-③<br>①-③<br><b>T<sub>R</sub><sup>1</sup><sub>2</sub></b> | 3 1x<br>      | 1 3<br> |

Robert Senior, 2010, The Sunday Class 1, RSCDS Book 48.2

3C/4C longwise set.

| <b>THE DANCING MASTER</b>           |  |                          |                          |                            | <b>96 J</b>                                              |
|-------------------------------------|--|--------------------------|--------------------------|----------------------------|----------------------------------------------------------|
| S<br>                               |  | <b>X<sub>R</sub></b><br> | 1 3<br>Chase 1 place<br> | 2 2<br>                    | 1 2<br>2 3<br><b>RA LA</b><br>4 3<br>1 4<br><b>RA LA</b> |
|                                     |  |                          |                          | 2 4<br><b>R</b><br>32 Bars |                                                          |
| ①-③<br>①-③<br><b>SX<sub>R</sub></b> |  | <b>RA</b><br>            | <b>R</b><br>             | Schiehallion Reel<br>      | 2<br>1 8 3<br>4                                          |

John Drewry, 1989, Donside Book

4C/4C square set.

| <b>THE CUCKOO CLOCK</b> |                                     |           |                                  |                                 | <b>8x32 R</b>                            |
|-------------------------|-------------------------------------|-----------|----------------------------------|---------------------------------|------------------------------------------|
|                         | 1 2<br>DOUBLE<br>FIGURE<br>OF EIGHT | 1 2 3<br> | 3x 1x 2x<br><b>T<sub>R</sub></b> | 3x 1x 2x<br><b>S &amp; LINK</b> | ②-③<br>①-①<br>②-③<br><b>S &amp; LINK</b> |

Ian Barbour, 1991, Dance and Celebration

3C/4C longwise set.

| <b>THE MINISTER ON THE LOCH</b> |                                               |                                   |                                                                                                      |                                                                                                      | <b>3x32 S</b> |
|---------------------------------|-----------------------------------------------|-----------------------------------|------------------------------------------------------------------------------------------------------|------------------------------------------------------------------------------------------------------|---------------|
| 1 2<br><b>P</b>                 | → <b>T<sub>B</sub></b> ← <b>T<sub>B</sub></b> | ① 2 ③<br>① 2 ③<br>Double Figure 8 | ①-② <b>T<sub>R</sub><sup>1</sup><sub>2</sub></b><br>①-② <b>T<sub>L</sub><sup>1</sup><sub>2</sub></b> | ①-③ <b>T<sub>L</sub><sup>1</sup><sub>2</sub></b><br>①-③ <b>T<sub>R</sub><sup>1</sup><sub>2</sub></b> |               |

Roy Goldring, 24 Graded & Social Dances, RSCDS 4/2008

3C/3C longwise set.

| <b>FATHER CONNELLY'S JIG</b>        |  |                           |                                     |                                     | <b>4x64 J</b> |
|-------------------------------------|--|---------------------------|-------------------------------------|-------------------------------------|---------------|
| Set & Rotate<br>1 2<br><b>S</b><br> |  | <b>X<sub>R</sub></b><br>  | <b>SX<sub>R</sub></b><br>           | <b>RL</b> <b>SX<sub>R</sub></b><br> | ③ ① ②<br>     |
| <b>SX<sub>R</sub></b><br>           |  | 2 3<br>                   |                                     |                                     |               |
| <b>SX<sub>R</sub></b><br>           |  | <b>SX<sub>R</sub></b><br> | <b>RL</b> <b>SX<sub>R</sub></b><br> |                                     | 6 or 8<br>    |

John Drewry, 1990, Donside Book

4C/4C longwise set.

| <b>THE FIREWORKS REEL</b> |                    |     |                    | <b>8x32 R</b> |
|---------------------------|--------------------|-----|--------------------|---------------|
| $X_R$                     |                    | $S$ | $T_{L\frac{3}{4}}$ |               |
| $S$                       | $T_{L\frac{3}{4}}$ |     | $3x\ 1x\ 2x$       |               |

Anselm Lingnau, 2009, my.strathspey.org/u/anselm/dances/, RSCDS Book 48.11 3C/4C longwise set.

| <b>THE GARDENERS' FANTASIA</b> |               |           |        | <b>3x32 S</b> |
|--------------------------------|---------------|-----------|--------|---------------|
| $S$                            | RONDEL $1\ 3$ | $S\ T$    | $RL$   |               |
| $1\ 2$                         | $1\ 2$        | $2\ 3\ 1$ | $2\ 1$ |               |

Pamela Cook, RSCDS Book 46.2 3C/3C longwise set.

| <b>MACLEOD'S FANCY</b>         |                    |              |                    | <b>4x32 J</b> |
|--------------------------------|--------------------|--------------|--------------------|---------------|
| $S$                            | $T_{R\frac{1}{2}}$ | $B$          | $T_{R\frac{1}{2}}$ |               |
| $1\ 2\ 3\ 4$                   | $1\ 2\ 3\ 4$       | $1\ 2\ 3\ 4$ | $1\ 2\ 3\ 4$       |               |
| $ALL$<br>$T_R$ to $2\ 4\ 1\ 3$ | $4\ 1$<br>$S$      |              |                    |               |

John Drewry, 1985, RSCDS Book 33.3 4C/4C longwise set.

| <b>GLASTONBURY TOR</b> |         |              |                     | <b>8x32 R</b> |
|------------------------|---------|--------------|---------------------|---------------|
| $S\ RA$                | $S\ LA$ | $S\ X_R$     | $T_L$               |               |
| $1\ 2$                 | $1x\ 3$ | $1\ 2\ 3\ 4$ | $1\ 2\ 3\ 4$        |               |
|                        |         | $S$ & LINK   | $T_{R1\frac{1}{2}}$ |               |

Duncan Brown, 2001, RSCDS Book 47.11 3C/4C longwise set.

| <b>A GIN AND TONIC</b> |                          |           |           | <b>3x32 S + 3x32 R</b> |
|------------------------|--------------------------|-----------|-----------|------------------------|
| Espagnole $S$          | $T_R\ T_{L1\frac{1}{4}}$ | $L+$      | $T_R$     |                        |
| $1\ 2$                 | $1\ 2$                   | $1\ 2\ 3$ | $3\ 1\ 2$ |                        |

Gordon Scott, 2011, Three Hands Across, RSCDS BHS Border 3C/3C longwise set.

| <b>THE IRISH ROVER</b> |           |                    |           | <b>8x32 R</b> |
|------------------------|-----------|--------------------|-----------|---------------|
| $2$                    | $RA$      | $T_{L\frac{3}{4}}$ | $3x\ 2x$  |               |
| $2$                    | $1\ 2\ 3$ | $1\ 2\ 3$          | $3\ 1\ 2$ |               |
| $2$                    | $1\ 2\ 3$ | $1\ 2\ 3$          | $3\ 1\ 2$ |               |

James B Cosh, 22 SCD & 1 other 3C/4C longwise set.