

HOOPER'S JIG		8x32 J				
ALL	1x3	ALL	1 2	1 2 3	2 1	
						RL

RSCDS MMM 2.12

3C/4C longwise set.

MAIRI'S WEDDING		8x40 R			
					2 1 3

James Cosh, 1959, 22 SCD & 1 other

3C/4C longwise set.

MACLEOD'S FANCY		4x32 J			
ALL		4 1			

John Drewry, 1985, RSCDS Book 33.3

4C/4C longwise set.

THE FINDLAYS' JIG		8x32 J			
		1 2 3	1	2	2 1 3



R Goldring, 2000, 14 Social Dances for 2000

3C/4C longwise set.

MRS STEWART'S JIG		8x32 J			
S	2 1x3	2 1x	2 1 3	2 1 3	T_R 1 1/2

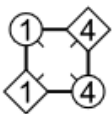
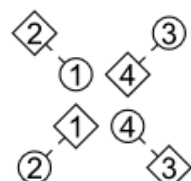
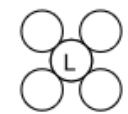
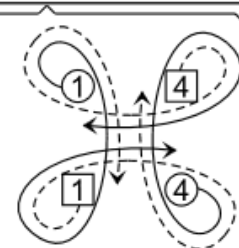
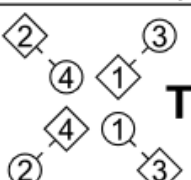
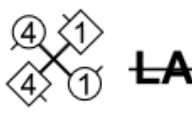
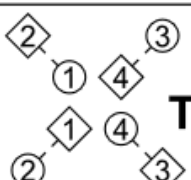

Frans Ligtmans, 1986, RSCDS Book 35.1

3C/4C longwise set.

REEL OF THE PUFFINS		3C & 4C cross on 2nd chord	4x32 R
1: X_R 1 4x: X_R 1	1x 4  S S	2 3x   	
 T_R	 LA	 T_R	1-4 X_L 1-4 2 4 1x 3x  



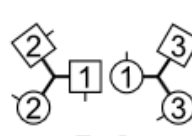
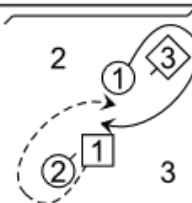
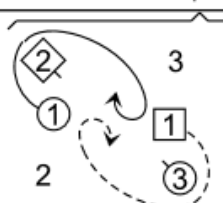
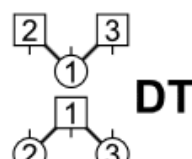

John Bowie Dickson, 1998, Dunedin Dances 5.1

4C/4C longwise set.

TRIP TO TIMBER RIDGE		8x32 R
T_R 1	 RA	Corners Pass & Turn  T_R
 T_R	 DT	2 1 3 

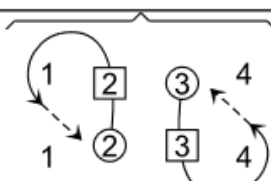
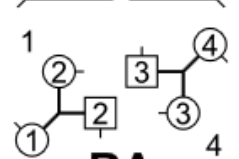
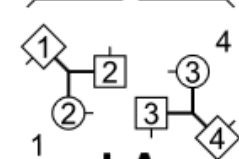
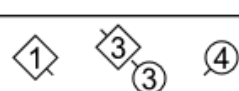

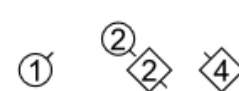
Linda Henderson, 2010, RSCDS Book 52.12

3C/4C longwise set.

LADY SOPHIA LINDSAY		3C & 4C cross on 2nd chord	4x32 R
2 3x RA		 RA	 LA
 	  to 2 1 4x 3x	1-4 S X_R -4 1-4 S X_R -4	4x 1 S X_R to 2 4 1x 3x

Jean Attwood, Alexander Leaflets

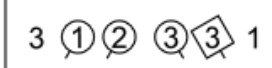
4C/4C longwise set.

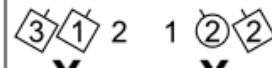
CASHMERE SHAWL		8x32 S
T_R 2 X_L 1	T_R T_L T_R T_L	
	2 T_L 2x1x3x  X_R	1 2 2 1 3 3 X_L

Iain Boyd, Strathtay Album

3C/4C longwise set.

THE GENTLEMAN			8x32 S		
<p>T_B</p>	<p>T_{L¹/₂}</p>	<p>T_{L¹/₂}</p>	<p>P</p>	<p>P</p>	<p>P</p>
<p>T_{L¹/₂}</p>	<p>P</p>	<p>P</p>	<p>P</p>	<p>P</p>	<p style="text-align: center;">2 1</p> <p style="text-align: center;">P</p>

Roz Scott Huxley, 1986, RSCDS Book 35.5

3C/4C longwise set.

MISS GIBSON'S STRATHSPEY				8x32 S		
<p style="text-align: center;">1 2</p> <p style="text-align: center;">S T_B</p>	<p style="text-align: center;">KNOT</p>	<p style="text-align: center;">1 2</p> <p style="text-align: center;">KNOT</p>	<p style="text-align: center;">RA</p>	<p style="text-align: center;">LA</p>	<p style="text-align: center;">RA</p>	<p style="text-align: center;">LA</p>

Derek Haynes, 1979, RSCDS Leaflet 10

3C/4C longwise set.

NEIDPATH CASTLE			3x32 S	
<p style="text-align: center;">ALL</p> <p style="text-align: center;">S T_{B2} S</p>	<p style="text-align: center;">ALL</p> <p style="text-align: center;">CHAIN</p>	<p style="text-align: center;">P</p>	<p style="text-align: center;">1 2</p> <p style="text-align: center;">P</p>	<p style="text-align: center;">1 3</p> <p style="text-align: center;">P</p>

Derek Haynes, RSCDS Book 22.9

3C/3C longwise set.