

<b>BEST SET IN THE HALL</b>				<b>8x32 J</b>	

Helen Greenwood, 2003, RSCDS Book 46.7

3C/4C longwise set.

<b>GLASTONBURY TOR</b>				<b>8x32 R</b>	
1 2 <b>S RA</b>	1x3 <b>S LA</b>	<b>S X<sub>R</sub></b> ↺ <b>T<sub>L</sub></b>			

Duncan Brown, 2001, RSCDS Book 47.11

3C/4C longwise set.

<b>RED HOUSE</b>				<b>8x40 R</b>	
<b>S</b> ↺ <b>S</b> ↺					

Walsh, 1731, RSCDS Book 7.2

2C/4C longwise set.

<b>STAIRCASE IN STYRIA</b>				<b>5x40 R</b>	
	<b>X<sub>R</sub></b> ↺		1x <b>X<sub>R</sub></b> ↺		

Margaret Gray

5C/5C longwise set.

<b>FINDLATER CASTLE</b>			<b>8x32 R</b>
2 1 3 	Set and Link for Three 		

Bill Forbes, 2004, Craigievar 5, Jubilee Book (Banffshire)

3C/4C longwise set.

<b>FISHERMAN GINGER'S REEL</b>			<b>8x32 R</b>
		2 1 3    ALL    ALL 	

Gaye and Damon Collin, 2001, SCD is all around the World

3C/4C longwise set.

<b>SCOTT MEIKLE</b>			<b>4x32 R</b>		
		1 3 <b>RA</b> <b>LA</b>		1 4 <b>RL</b>	4x 1x <b>T<sub>R</sub>1<sup>1/2</sup></b>

Alice McLean, Laurieston Collection 1, RSCDS Book 46.3

4C/4C longwise set.

<b>THE KELPIE OF LOCH CORUISK</b>			<b>7x32 R</b>
1 3 5 			
		1 3 5 <b>T<sub>R</sub>3<sup>3/4</sup></b>	

Barry Priddey, Silver Rose Book

7C/7C longwise set.

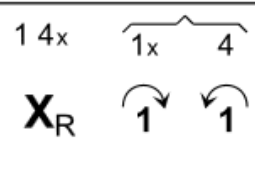
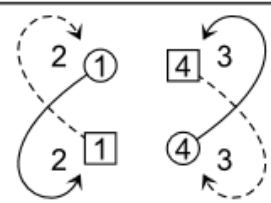
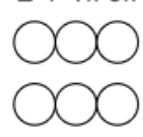
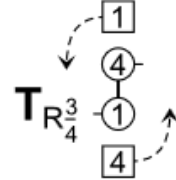
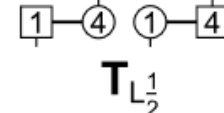
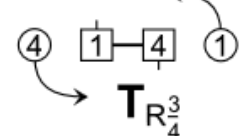
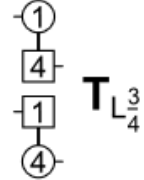
<b>JAMES GRAY</b>		3C & 4C cross on 2nd chord		<b>4x32 J</b>	
1 4x <b>X<sub>R</sub></b> 		1 4x <b>RL</b>	2 1 4x 3x 		
			 to 2 4 1x 3x		

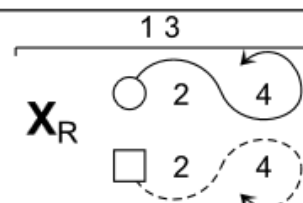
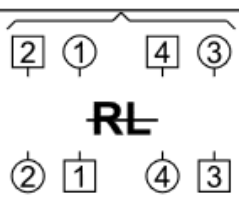
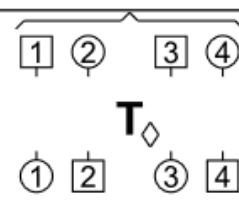
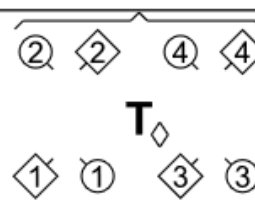
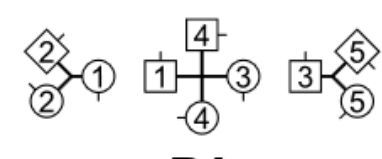
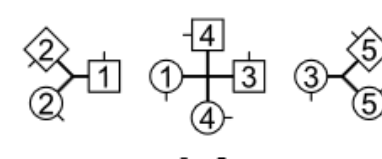

Ronella Burrows, RSCDS Book 42.10

4C/4C longwise set.

<b>THE PLANTATION REEL</b>		<b>5x32 R</b>			
1 3 <b>X<sub>R</sub></b> 	 <b>RL</b>	 <b>T<sub>◇</sub></b>	 <b>T<sub>◇</sub></b>		
 <b>RA</b>	 <b>LA</b>	1x 3x <b>X<sub>R</sub></b> 1	2 4 1 5 3 <b>T<sub>R</sub></b>		

Tony Moretti, Pinewoods 2

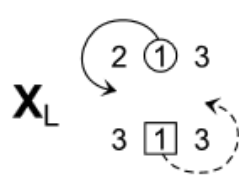
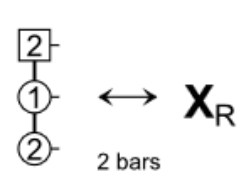
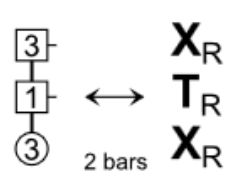
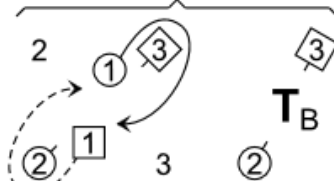
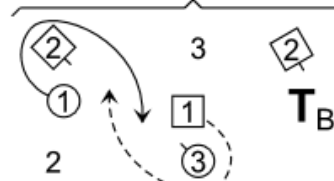
5C/5C longwise set.

<b>THE FALKIRK LASS</b>		<b>8x32 S</b>			
<b>T<sub>R</sub></b> 1	<b>X<sub>L</sub></b> 	 2 bars <b>X<sub>R</sub></b>	 2 bars <b>X<sub>R</sub></b>	<b>X<sub>R</sub></b> 2 <b>T<sub>R</sub></b> 1 <b>X<sub>R</sub></b> 2	
Corners Pass & Turn	 <b>T<sub>B</sub></b>	 <b>T<sub>B</sub></b>	2 1 3 		

Elaine Brunken, Merse Collection, Moments in Time

3C/4C longwise set.

<b>CITY OF BELFAST</b>		<b>3x32 S</b>
		<p style="text-align: center;">Espagnole</p>

Lucy Mulholland, 2007, Belfast Diamond Jubilee Book, RSCDS Book 48.6

3C/3C longwise set.

<b>CULLEN SKINK</b>		3C & 4C on opposite sides	<b>4x32 S</b>
<p>1 2 3x 4x</p> <p style="text-align: center;"><b>S</b></p>	<p>4x 1</p> <p style="text-align: center;"><b>RA</b></p>		
		<p>2 4 1 x 3x</p> <p style="text-align: center;">4</p>	

John Drewry, 1999, Greenburn Book 2

4C/4C longwise set.