

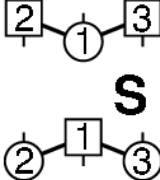

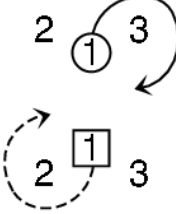

THE SAILOR					8x32 R	
	 <p style="text-align: center;">S</p>	 <p style="text-align: center;">S</p>		<p>1x</p> 		<p>2 1</p> <p>RL</p>

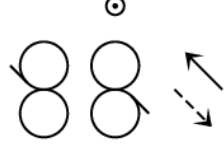
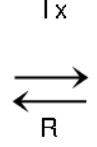
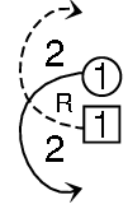
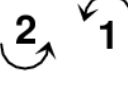
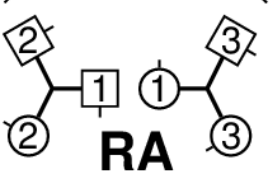

RSCDS Book 24.4

3C/4C longwise set.

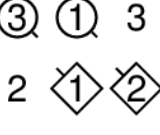
THE IRISH ROVER					8x32 R	
	 <p style="text-align: center;">RA</p>	 <p style="text-align: center;">T_L^{3/4}</p>	<p>3x</p> 	<p>2x</p> 	 <p style="text-align: center;">RL</p>	 <p style="text-align: center;">RL</p>

James B Cosh, 22 SCD & 1 other

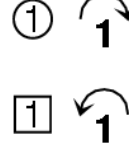
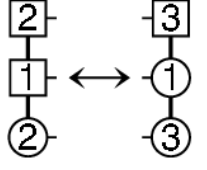
3C/4C longwise set

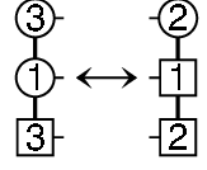
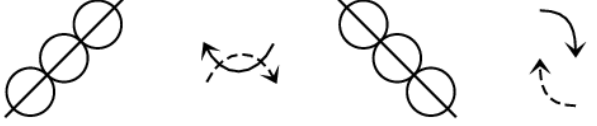
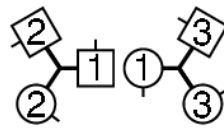
THE SPRING FLING REEL					8x40 R	
<p>T_R</p> 	<p>X_R</p> 				<p>T_R^{1 1/4}</p>	
			 <p style="text-align: center;">LA</p>		<p>2 1x 3</p> <p>T_L T_R^{1 1/2} T_L</p>	

Samantha Burton, 2014, RSCDS Book 50.1

3C/4C longwise set.

THE PLANTATION REEL 5x32 R

<p>X_R</p>	<p>2 1 4 3</p> <p>RL</p> <p>2 1 4 3</p>	<p>1 2 3 4 2 2 4 4</p> <p>T_◇</p> <p>1 2 3 4 1 1 3 3</p>	
<p>RA</p>	<p>LA</p>	<p>1x 3x</p> <p>X_R 1</p>	<p>2 4 1 5 3</p> <p>T_R</p>

Tony Moretti, Pinewoods 2

5C/5C longwise set

REEL OF THE PUFFINS 3C & 4C cross on 2nd chord **4x32 R**

<p>1: X_R 1</p> <p>4x: X_R 1</p>	<p>1x 4</p> <p>S S</p>	<p>2 3x</p>	
<p>T_R</p>	<p>LA</p>	<p>1-4</p> <p>X_L</p> <p>1-4</p>	<p>2 4 1x 3x</p>

John Bowie Dickson, 1998, Dunedin Dances 5.1

4C/4C longwise set.

THE RUTLAND REEL **8x40 R**

<p>S 1</p>	<p>R</p>	<p>2 1x</p>	<p>2 1x 3</p>	<p>1-3</p> <p>1-3</p> <p>T_R¹₂</p>	<p>3 1x</p>	<p>3 1</p>	<p>1 3</p>
-------------------	-----------------	-------------	---------------	---	-------------	------------	------------

Robert Senior, 2010, The Sunday Class 1, RSCDS Book 48.2

3C/4C longwise set.

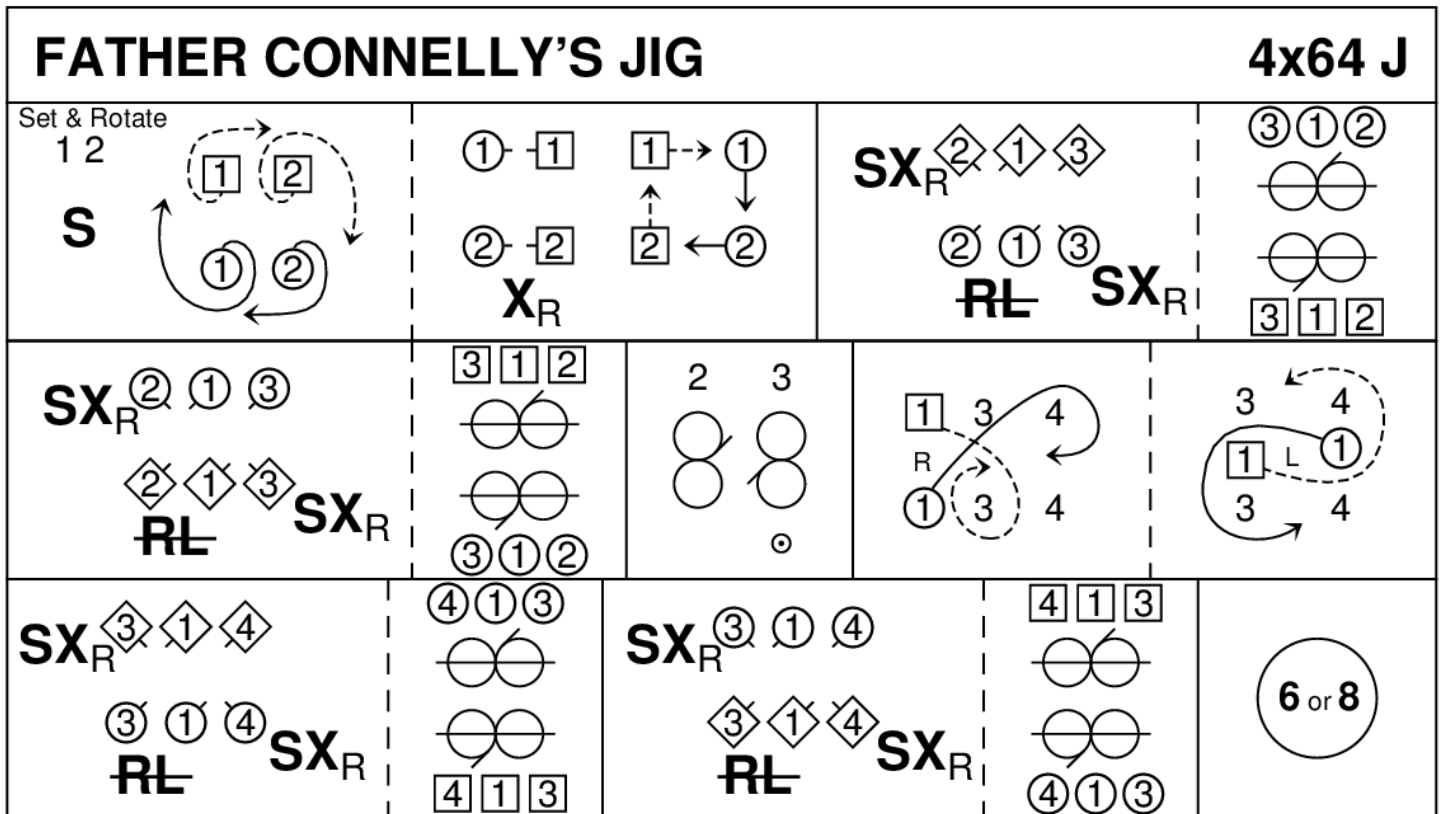

John Drewry, 1990, Donside Book

4C/4C longwise set.

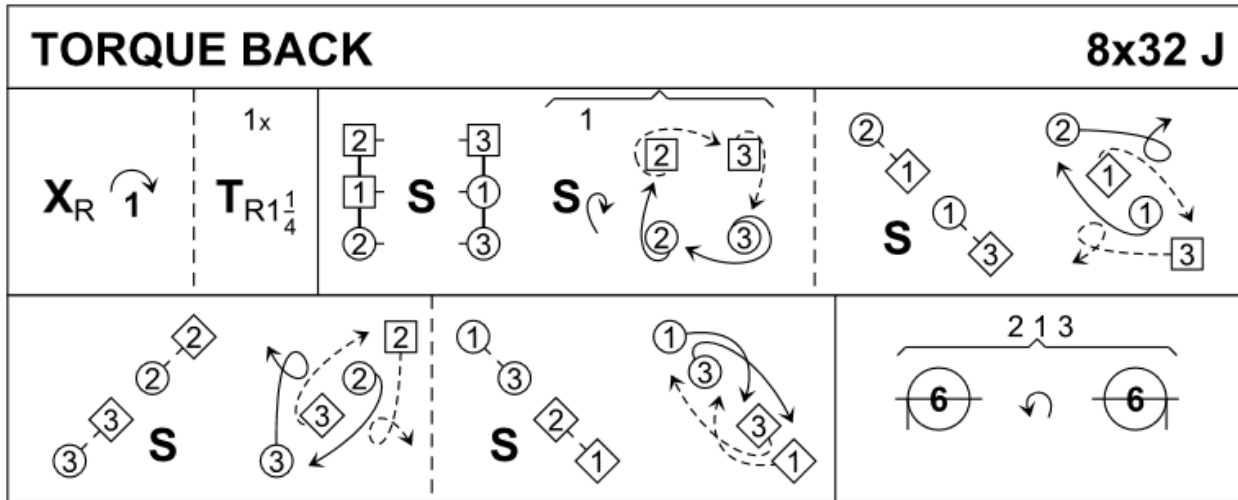

Murrough Landon, 2017, <https://my.strathspey.org/u/murrough/TorqueBack.pdf>

3C/4C longwise set.

JAMES GRAY		3C & 4C cross on 2nd chord		4x32 J	
1 4x X_R 		1 4x RL	2 1 4x 3x 		
			to 2 4 1x 3x		

Ronella Burrows, RSCDS Book 42.10

4C/4C longwise set.

KYLE CASTLE		4x32 S	
Extended Espagnole			
	4 3x 2x 1 S & LINK		2 4 1 3 RA to: 2 4 1 3

Murrough Landon, 2017, my.strathspey.org/u/murrough/KyleCastle.pdf

4C/4C longwise set.

LINNEA'S STRATHSPEY		8x32 S	
S		S	S
Chaperoned Chain Progression			
			3 1 2 A to 2 1 3

Tim Wilson, 2001, Dunsmuir Dances, RSCDS Book 47.2

3C/4C longwise set.