

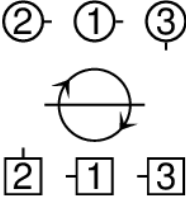



St ANDREW'S FAIR					8x32 J	
$X_R \curvearrowright 2 \quad X_L \curvearrowleft 1$	$\overbrace{2 \ 1 \ 3}$ $T_{R\frac{1}{2}} \ S$ retain hands		$3 \ 1 \ 2$ 	$\overbrace{3 \ 1 \ 2}$ $T_{L\frac{1}{2}} \ S$ retain hands		

R Goldring, 1980, RSCDS 5/1982

3C/4C longwise set.

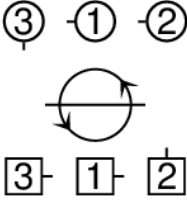
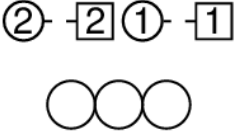
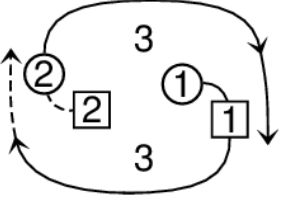
SWISS LASSIE					8x32 R	
$\curvearrowright 2$	$2 \ 1$ $T_{R1\frac{1}{4}}$			$1 \ 3 \ 2$ 	$3 \ 2$ $T_{R\frac{1}{2}} \ RA$	$1 \ 2$ $T_{R\frac{1}{2}} \ RA$

Rosi Betsche, RSCDS Book 39.1

3C/4C longwise set.

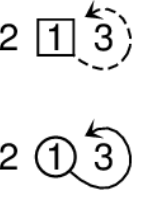
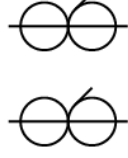
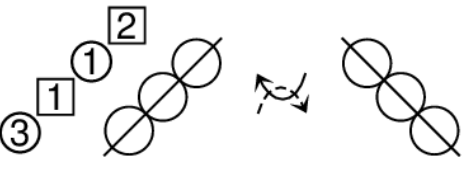
THE GRUMPY GENTLEMAN					8x32 J	
$1 \ 2$ S & ROTATE				$\overbrace{2x \ 1x \ 3x}$ $S_2 \ T_{R\frac{1}{2}} \ Twirl$		

Gillian Jennings, Birmingham Diamond Jubilee

3C/4C longwise set.

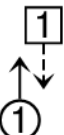
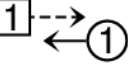
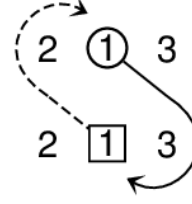
EH3 7AF					8x32 J	
	$1 \ 2 \ 3$ $PROM \ \curvearrowright 1$	 T_R	 T_R	$2 \ ① \ \boxed{1} \ 3$ RA		

Roy Goldring, 1998, RSCDS Book 40.6

3C/4C longwise set.

TRIP TO GATLINBURG			8x32 J
1 2 RA LA			2 1 3 (6)

Shengzhang Tang, 1994

3C/4C longwise set.

BILL CLEMENT MBE			8x32 J
			T _L
		T _R	2 1 3 (6)

John Wilkinson, 2008, RSCDS Book 47.1

3C/4C longwise set.

RED HOUSE			8x40 R
S 1 S 1			

Walsh, 1731, RSCDS Book 7.2

2C/4C longwise set.

TOMALENA			5x32 R
1 3 ⇌			1 4 3 5 P

Sara Gratiot & Paul Douglas, 1984, San Francisco 2

5C/5C longwise set.

TEMPEST IN A TEACUP		2C begin on opposite sides		3x64 R
1 2x RL		Target 		
	2 1x 3 	1x 3 RL		Target

Terry Glasspool, Strathspey Anniversary Collection

3C/3C longwise set.

AUTUMN IN APPIN		3C & 4C cross on 2nd chord		4x32 S
2 3x T_◇ S T_{R³/₄} RA	1 4x 			
	4 1 	2x 3 T_{R¹/₂}		
	4 1 		Spiral bar 6 to long set 2 4 1x 3x	

John Drewry, 1982, RSCDS Book 31.5

4C/4C longwise set.

HELLO-GOODBYE				8x32 S
S X_R	1 			
		LA	RA	

Chris Ronald, 2012, RSCDS Book 51

3C/4C longwise set.

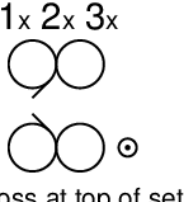
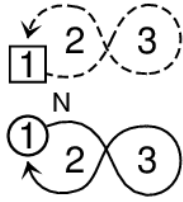
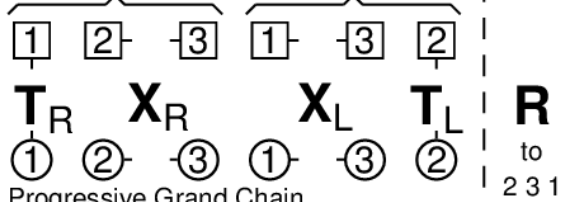
DAGMAR'S FANCY		3x32 S	
ALL T_◇ S T_{R³/₄} S	1x 2x 3x 		

Anselm Lingnau, 1993, Mainhattan Book

3C/3C longwise set.

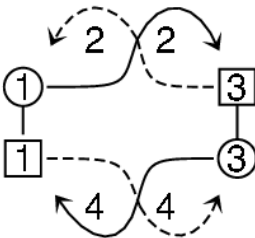
JOHNNIE WALKER		64 S + 64 J	
	ALL ST_R	ALL ST_L	
LADIES T_◇ 1 place R	ALL S	R	MEN R
GRAND CHAIN	A	REPEAT IN JIG TIME	

Norman & Helen Robson, 1977, Whisky Collection

4C/4C square set.